

6~Flange Screws M6 x 30 Removal Of These Will Enable The End Covers And Tubestack To Be Removed.

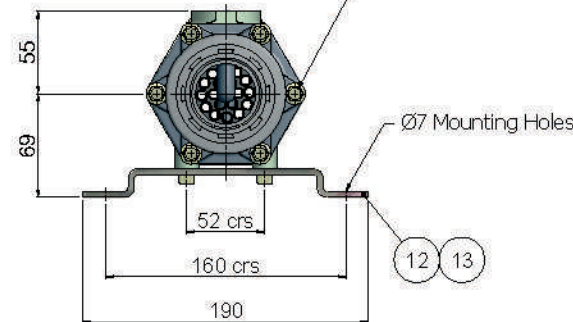

Notes:  
 Item No's. 5, 6 7 And 8 Supplied Loose With Assembly.  
 4~M6 x 12 Socket Screws Supplied Fitted Into Mounting Feet.  
 Body To Be Painted Swimming Pool Green.  
 \* Drawing No. Suffix To Indicate Tube Material, C=Cupro Nickel Tube, S=Stainless Steel Tube And T=Titanium Tube.

|          |         |        |                     |            |          |    |
|----------|---------|--------|---------------------|------------|----------|----|
|          | M6 x 12 | 4      | Socket Screws       | 13         | M5       |    |
|          | 4154    | 2      | Mounting Feet       | 12         | SS       |    |
|          | 3594    | 1      | Nameplate           | 11         | Brass    |    |
|          | M6 x 30 | 12     | Flange Screws       | 10         | M5       |    |
|          | AN12    | 2      | Seals               | 9          | Nitrile  |    |
|          |         | 2      | Union Bush (B5)     | 8          | GFN      |    |
|          | 5134    | 2      | Union Bush (Metric) | 7          | GFN      |    |
|          |         | 2      | Union Seals         | 6          | EPDM     |    |
|          |         | 2      | Union Nuts          | 5          | GFN      |    |
|          | 4571    | 4      | Split Rings         | 4          | GFN      |    |
|          | 4567    | 2      | End Covers          | 3          | GFN      |    |
|          | 5095-2  | 1      | Tubestack EC100     | 2          | *        |    |
|          | EC70    | 4568-2 | 1                   | Body EC100 | 1        | CI |
| Part No. | Drg No. | Qty    | Description         | Item       | Material |    |

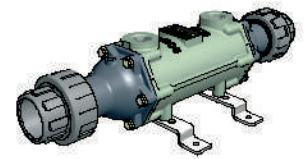
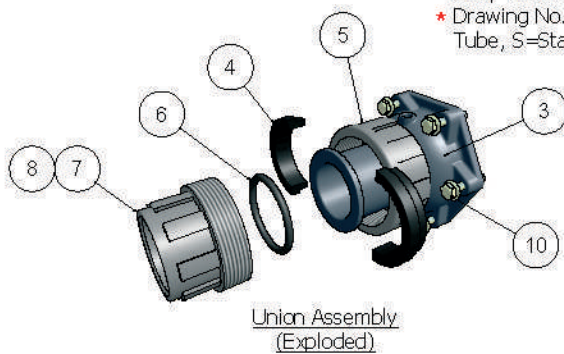

ALL DIMENSIONS ARE IN MILLIMETRES

**E.J. BOWMAN (BERMINGHAM) LTD.**  
 Chester Street Birmingham B6 4JF England  
 Tel: +44 (0) 121 255 5555 Fax: +44 (0) 121 255 7145  
 email: info@ejbowman.co.uk www.ejbowman.co.uk

|           |            |        |          |
|-----------|------------|--------|----------|
| DRAWN:    | DS/sgk     | FILE:  |          |
| DATE:     | 20/11/2009 |        |          |
| DESIGNED: |            |        |          |
| CHKD:     |            |        |          |
| CHECKED:  |            | DRGNO: | 5113-2 * |
| SCALE:    | 1:1        |        |          |

**BOWMAN 40**  
TITAN